



TOUCHSCREEN DISPLAY TECHNOLOGY

YOUR IN-DEPTH GUIDE



TOUGHBOOK

WHAT IS... A CAPACITIVE TOUCHSCREEN?

A capacitive touchscreen panel is coated with a material that stores electrical charges. When the panel is touched, a small amount of charge is drawn to the point of contact. Circuits located at each corner of the panel measure the charge and send the information to the controller for processing.

Capacitive touchscreen panels must be touched with a finger, unlike resistive and surface wave panels that can be operated by either fingers or stylus. Capacitive touchscreens aren't affected by outside elements and have high clarity.

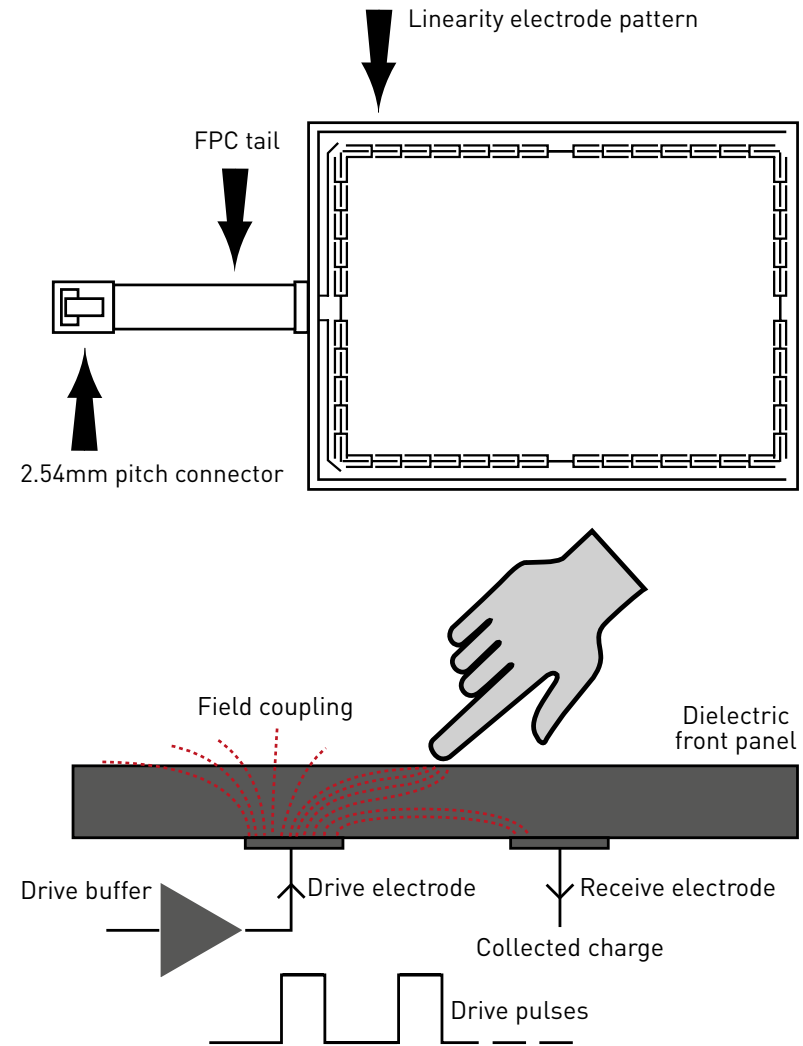
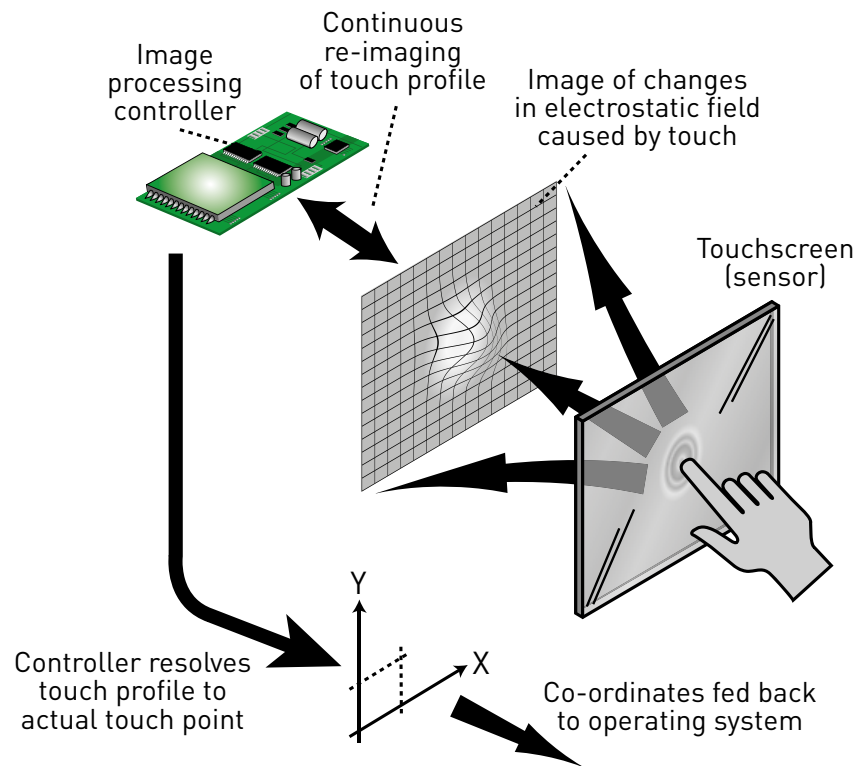

WHAT IS...

A DIGITISER TOUCHSCREEN?

Digitiser touchscreens make use of electromagnetic induction technology, where the horizontal and vertical wires of the screen operate as both transmitting and receiving coils. The tablet generates an electromagnetic signal, which is received by the stylus. The wires in the tablet then change to a receiving mode and read the signal generated by the stylus.

Modern arrangements also provide pressure sensitivity and one or more switches (similar to the buttons on a mouse), with the electronics for this information present in the stylus itself, not the tablet.

By using electromagnetic signals, the tablet is able to sense the stylus position without the stylus having to even touch the surface, and powering the pen with this signal means that devices used with the tablet never need batteries.

The core benefit of this type of screen is the accuracy of the digitiser pen. So detailed drawings and signatures are possible. What's more, because a special digitiser pen is needed, the touchscreen can't be used with fingers or hands, eliminating accidental input errors.

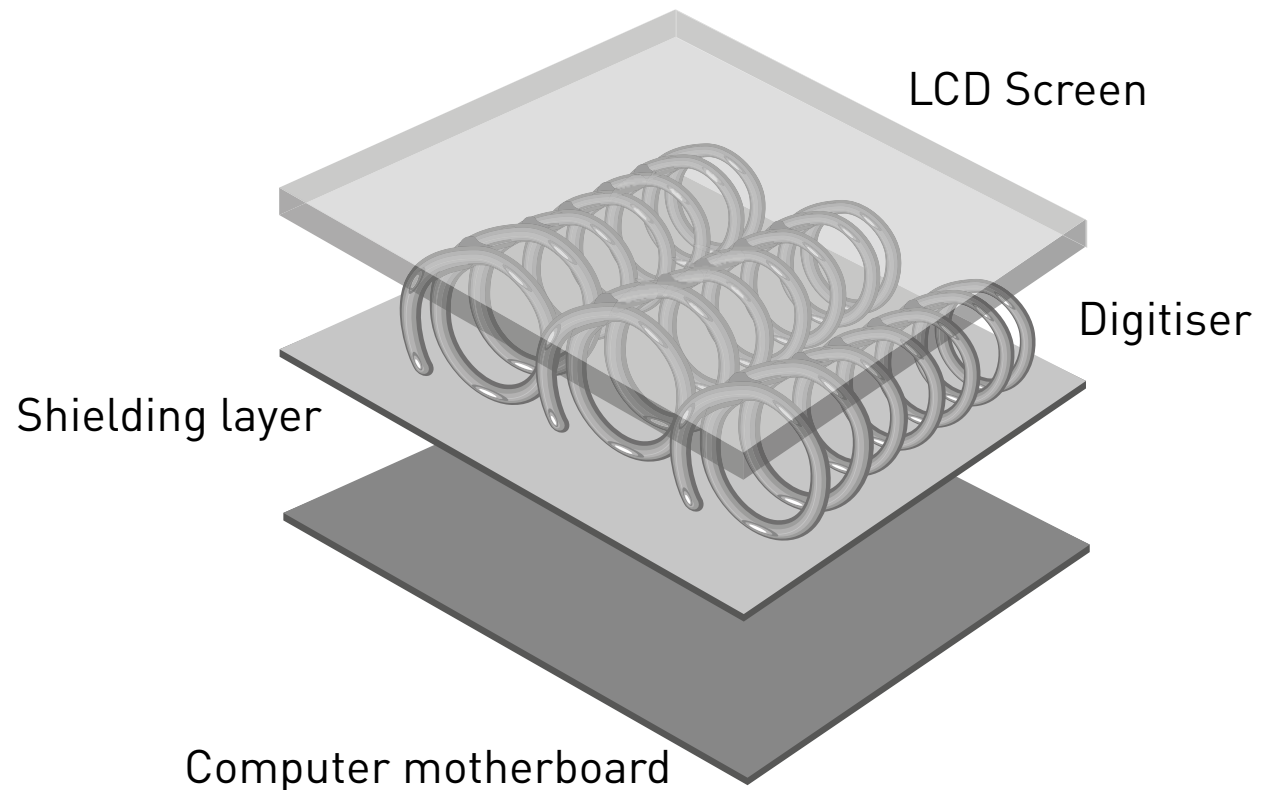

WHAT IS... DUAL TOUCH?

Dual touch is the combination of capacitive touchscreen and digitiser technology. It enables the operator to use the GUI with fingers, as well as with a digitiser pen. The key benefit of this combination is the intuitive handling via finger and the accuracy (signature capture, handwriting recognition) of the pen providing the flexibility to choose the right display input mode on demand.

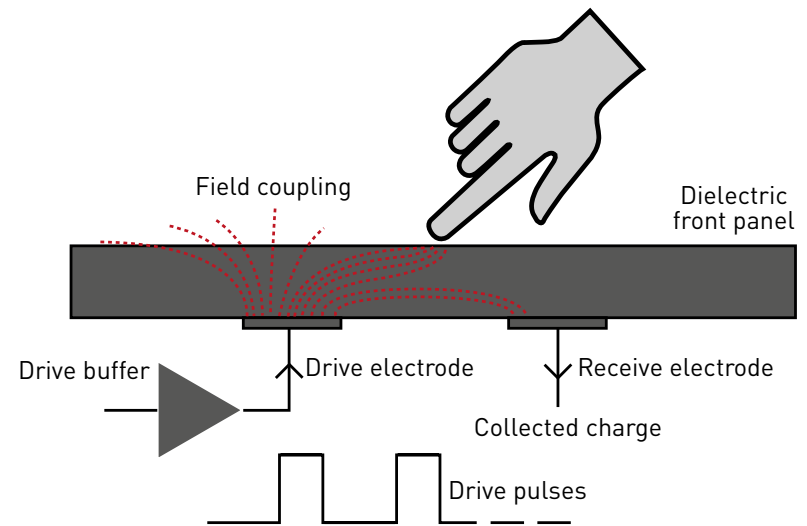
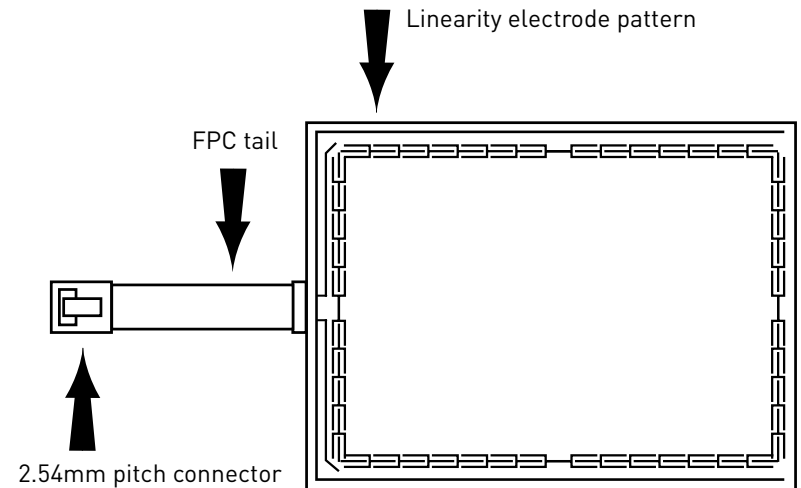
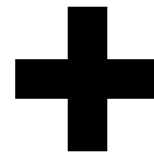
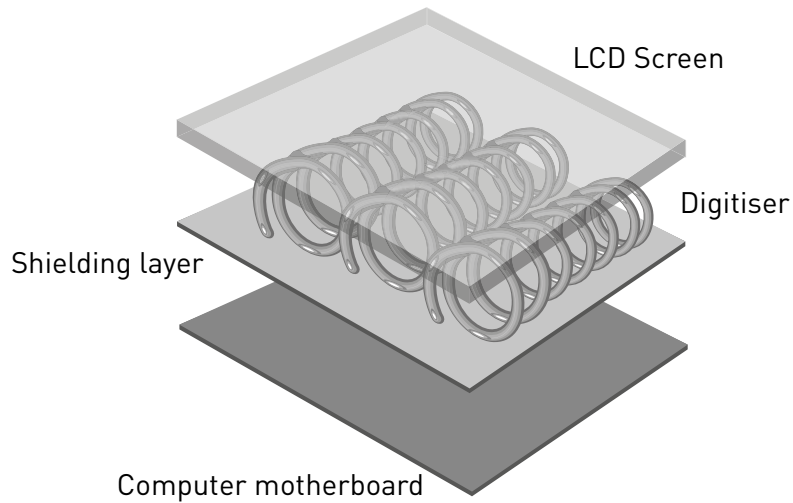

WHAT IS... MULTI-TOUCH?

Multi-touch is a method of input on a touchscreen that allows two or more fingers to be used on the screen at one time. Multi-touch allows pinching and stretching gestures on the screen to control zooming.

A multi-touch display is pressure sensitive, as well as gesture sensitive, which are predefined motions that are commands to perform an action, such as rotate the object on the z-axis.

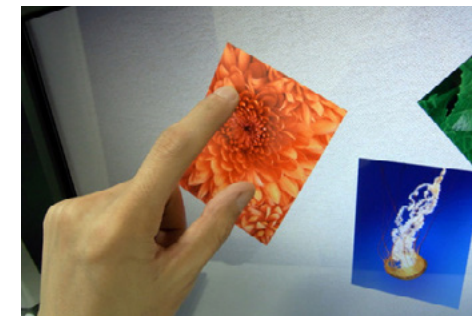

WHAT IS... IPS?

In IPS (In-Plane Switching) technology the liquid crystal runs horizontally, giving it a wide viewing angle, fast response speed and a simple pixel structure.

IPS panels employ pairs of electrodes at the sides of each cell, running the electric field horizontally through the material. This approach keeps the liquid crystals parallel to the front of the panel, increasing the viewing angle.

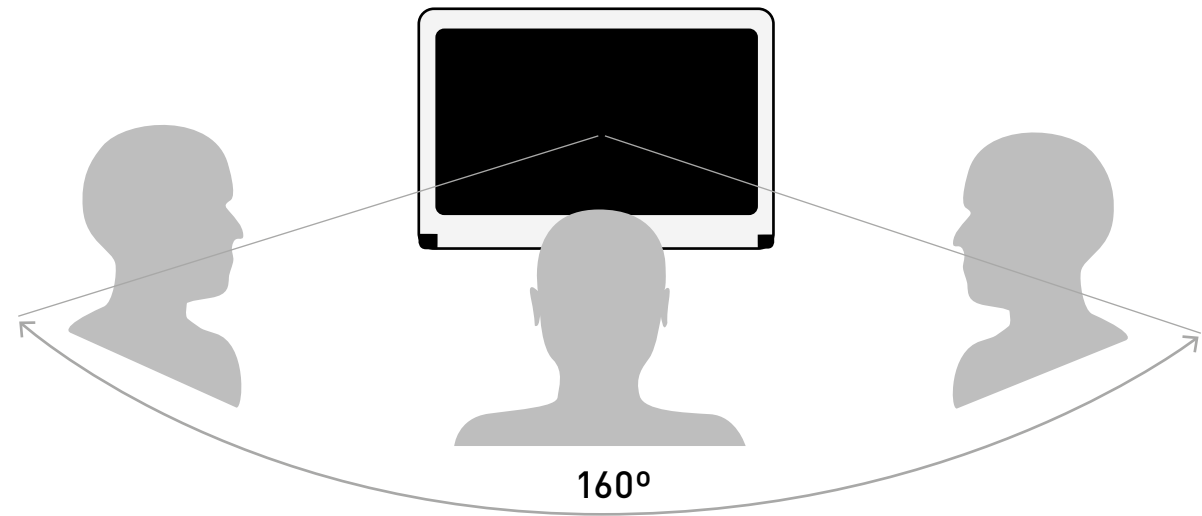

IPS PANEL DESIGN

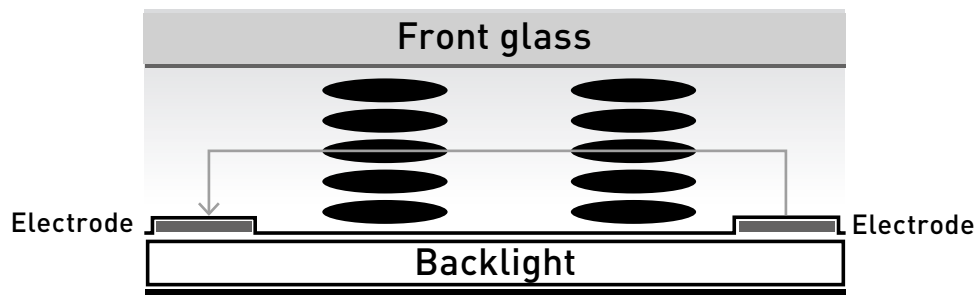

WHAT IS... IPS α ?

Transmittance

Point of image quality

Front view of a pixel (red, green, blue)

IPS-PRO

x1.0

- High transmittance
- High contrast ratio
- Wide viewing angle

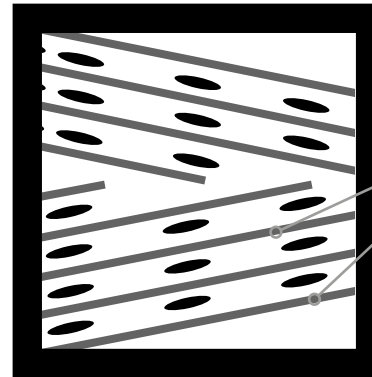

Fine pitch ITO
(Indium Tin Oxide)

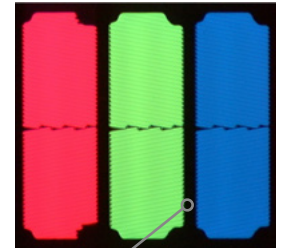

IPS α

x1.5

- High resolution
- High transmittance
- High contrast ratio
- Wide viewing angle

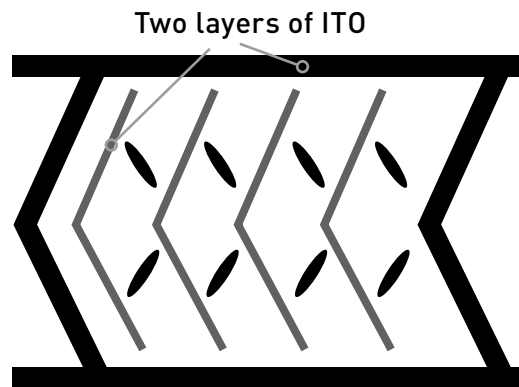

Two layers of ITO

Lines are shielded

Black space
is smaller than
IPS-Pro II

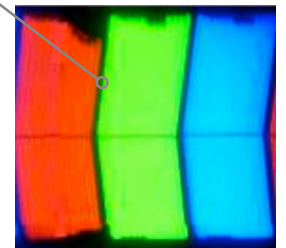

THE TOUCHSCREEN RANGE CONFIGURATIONS

Model	TOUGHBOOK 20	TOUGHBOOK 33
	Touchscreen	Touchscreen
Input device	Capacitive Multi-Touch	Capacitive Multi-Touch + Digitiser
Display brightness	800 cd/m ²	1.200 cd/m ²
IPS	✓	✓
IPS α		
Dual touch	Optional	✓
Anti-glare	✓	✓
Anti-reflection	✓	✓
Protection film	✓	✓
Direct bonding	✓	✓
Multi-touch	Ten-finger	Ten-finger
Standard signatures	✓	✓
High-res drawings and signatures	Optional, Dual Touch	✓
Gloves	✓	✓



TOUGHBOOK 20



TOUGHBOOK 33

THE TOUCHSCREEN RANGE CONFIGURATIONS

Model	TOUGHBOOK 55
	Full HD Model with Touchscreen
Input device	Capacitive Multi-Touch
Display brightness	1.000 cd/m ²
IPS	✓
IPS α	
Dual touch	
Anti-glare	✓
Anti-reflection	✓
Protection film	✓
Direct bonding	✓
Multi-touch	Ten-finger
Standard signatures	✓
High-res drawings and signatures	
Gloves	✓



TOUGHBOOK 55

THE TOUCHSCREEN RANGE CONFIGURATIONS

Model	TOUGHBOOK A3	TOUGHBOOK G1
	Touchscreen	Touchscreen
Input device	Capacitive Multi-Touch	Capacitive Multi-Touch + Digitiser
Display brightness	500 cd/m ² typical (800 cd/m ² max)	800 cd/m ²
IPS	✓	
IPS α		✓
Dual touch		✓
Anti-glare	✓	✓
Anti-reflection	✓	✓
Protection film	✓	✓
Direct bonding	✓	✓
Multi-touch	Ten-finger	Ten-finger
Standard signatures	✓	✓
High-res drawings and signatures		✓
Gloves	✓	✓



TOUGHBOOK A3



TOUGHBOOK G1

THE TOUCHSCREEN RANGE CONFIGURATIONS

Model	TOUGHBOOK L1	TOUGHBOOK M1
	Touchscreen	Touchscreen
Input device	Capacitive Multi-Touch	Capacitive Multi-Touch
Display brightness	350 cd/m ²	700 cd/m ²
IPS	✓	✓
IPS α		
Dual touch		
Anti-glare	✓	✓
Anti-reflection	✓	✓
Protection film	✓	✓
Direct bonding	✓	✓
Multi-touch	Ten-finger	Ten-finger
Standard signatures	✓	✓
High-res drawings and signatures		
Gloves	✓	✓



TOUGHBOOK L1



TOUGHBOOK M1

THE TOUCHSCREEN RANGE CONFIGURATIONS

Panasonic
BUSINESS

Model	TOUGHBOOK N1	TOUGHBOOK T1
	Touchscreen	Touchscreen
Input device	Capacitive Multi-Touch	Capacitive Multi-Touch
Display brightness	500 cd/m ²	420 cd/m ²
IPS	✓	✓
IPS α		
Dual touch		
Anti-glare	✓	✓
Anti-reflection	✓	✓
Protection film	✓	✓
Direct bonding	✓	✓
Multi-touch	Ten-finger	Ten-finger
Standard signatures	✓	✓
High-res drawings and signatures	Optional	
Gloves	✓	✓



TOUGHBOOK N1



TOUGHBOOK T1

www.mruggedmobile.com | sales@mruggedmobile.com | 877-870-3805

Panasonic and TOUGHBOOK are brand names and registered trademarks of Panasonic Corporation. Intel, the Intel logo, Intel Core, Intel vPro, Core Inside and vPro Inside are trademarks of Intel Corporation in the U.S. and other countries. Google, the Google logo, YouTube and Android are trademarks of Google Inc. Microsoft® and Windows® are registered trademarks of Microsoft Corporation of the United States and/or other countries. All other brand names shown are the registered trademarks of the relevant companies. All rights reserved.

Mobile Solutions Business Division – Europe Panasonic System Communications Company Europe (PSCEU), Panasonic Marketing Europe GmbH, Hagenauer Straße 43, 65203 Wiesbaden (Germany).

TOUGHBOOK